



ARTICULATED LOADERS



608 ▲ 708

FEATURES

▲ **POWER** and ▲ **PERFORMANCE**

THE Mustang HERD IS GETTING **BIGGER**



HIGH-IMPACT BUCKET BREAKOUT

These machines offer some of the highest breakout forces in their respective classes, allowing you to fill the bucket to the max with each scoop, increasing productivity output.



PROPORTIONAL AUXILIARY HYDRAULICS Proportional auxiliary hydraulics are standard equipment and put to work with a rocker switch on the joystick. Detent and pressure relief are included to optimize attachment hook-up and performance.

POWER-A-TACH®

The Power-A-Tach® hydraulic attachment system is standard equipment and features a skid steer interface to utilize the attachments you already own.

**45°
ARTICULATION**

FULL TURN TIP CAPACITY

608 (4-Post)	4,917 lbs. [2230 kg]
608 (Cab)	5,244 lbs. [2379 kg]
708 (4-Post)	5,778 lbs. [2621 kg]
708 (Cab)	6,126 lbs. [2779 kg]



INCHING PEDAL

The inching pedal offers maximum precision speed control, while maintaining the full force needed to lift the load.



MUSTANG®

LIFT HEIGHT

608	130.5" [3315 mm]
708	136.8" [3474 mm]



KING OF COMFORT

A seven-way adjustable seat, multi-function joystick, fully-adjustable steering column and cup holder are just a taste of the ergonomic features available in the cab.



MIGHTY MANEUVERS

Articulated steering brings a tight turning radius to speed up cycle times and increase maneuverability in tight areas.

FRONT & REAR LOCKING DIFFERENTIALS

Conveniently located on the joystick, one button will activate four wheel drive for maximum tractive effort when pushing into a pile.

EASY ENTRY

A low, non-slip step is essential for tasks requiring the operator to frequently enter and exit the machine.

FEATURES	4-POST	CAB	4-POST	CAB
	608	708	608	708
STRUCTURE				
4-Post Canopy - ROPS/FOPS Certified	○		○	
4-Post Canopy with Front and Rear Windows	●		●	
Cabin with Heat		●		●
Cabin with Heat and Air Conditioning		●		●
PERFORMANCE				
Power-A-Tach® Attachment Mounting System (Skid Steer Interface)	○	○	○	○
Proportional Auxiliary Hydraulics with Case Drain and Circuit Pressure Dump	○	○	○	○
Tapered Z-bar Loader Linkage with Mechanical Self-Level and Return-to-Dig	○	○	○	○
Hydraglide™ Ride Control	●	●	●	●
Rear Auxiliary Hydraulics	●	●	●	●
Additional Set of Front Auxiliary Hydraulics	●	●	●	●
High-Flow Auxiliary Hydraulics	●	●	●	●
Hydrostatic 2-Speed Transmission	○	○	○	○
Tilt and Lift Arm Float Detent with Detent Disable	○	○	○	○
Oscillating Front Frame	○	○	○	○
Differential Lock (Hydraulically Activated Front and Rear)	○	○	○	○
Electric Attachment Control 14-Pin Harness with Switches	●	●	●	●
Articulation Locking Bar (conforms to SAEJ276)	○	○	○	○
3-Speed	608 7 / 12 / 19 mph (11 / 20 / 30 km/hr)	708 5 / 12 / 19 mph (8 / 20 / 30 km/hr)	●	●
Inching Pedal	○	○	○	○
Rear Mount - Clevis	●	●	●	●
Rear Mount - Receiver	●	●	●	●
ENGINE				
Engine Block Heater	●	●	●	●
ELECTRICAL SYSTEM				
Lift / Tilt Electronic Lockout Switch	○	○	○	○
Master Electrical Disconnect Switch	○	○	○	○
Emergency Lift Arm Lower Switch	○	○	○	○
OPERATOR STATION				
Digital Display with Audible and Visual Indicators	○	○	○	○
Multi-Function Joystick	○	○	○	○
Steering Column with Tilt and Extension Adjustments	○	○	○	○
Cup Holder	○	○	○	○
Horn	○	○	○	○
Seven-Way Adjustable Mechanical Seat	○	○	○	○
Seven-Way Adjustable Air Suspension Seat	●	●	●	●
Adjustable Arm Rest	○	○	○	○
3 inch (75 mm) Seatbelt	●	●	●	●
Removable Rubber Floormat	○	○	○	○
12-Volt Socket in Arm Rest	○	○	○	○
Front and Rear 12-Volt Electric Auxiliary	●	●	●	●
Side View Mirrors	○	○	○	○
Lockable Tool Box	●	●	●	●
Radio	●	●	●	●
Back-up Alarm	●	●	●	●
Speed Control	●	●	●	●
Reverse and Brake Tail Lights	○	○	○	○
WORK LIGHTS				
Rotating Beacon	○	○	○	○
Strobe Light	○	○	○	○
LED Work Lights	○	○	○	○

○ STANDARD ● OPTIONAL

	608 - Canopy	608 - Cab	708 - Canopy	708 - Cab	
DIMENSIONS	A. Length with Bucket on Ground (mm)	199.9" (5077)	199.9" (5077)	205.5" (5220)	205.5" (5220)
	B. Shipping Length (mm)	167.7" (4260)	167.7" (4260)	174.9" (4443)	174.9" (4443)
	C. Front Wheel Center to Pivot Pin (mm)	32.8" (833)	32.8" (833)	36.7" (931)	36.7" (931)
	D. Wheelbase (mm)	79" (2007)	79" (2007)	81.2" (2063)	81.2" (2063)
	E. Rear Overhang (mm)	52.2" (1326)	52.2" (1326)	52.1" (1323)	52.1" (1323)
	F. Height to Top of Cab (mm)	97.1" (2467)	97.1" (2467)	97.5" (2476)	97.5" (2476)
	H. Hood Height (mm)	69.9" (1775)	69.9" (1775)	69.6" (1768)	69.6" (1768)
	J. Maximum Operating Height (mm)	157.8" (4008)	157.8" (4008)	163.8" (4160)	163.8" (4160)
	K. Bucket Hinge Pin Height (mm)	130.5" (3315)	130.5" (3315)	136.8" (3474)	136.8" (3474)
	L. Ground Plane to Bucket Edge Height (mm)	123" (3125)	123" (3125)	129" (3280)	129" (3280)
	M. Dump Clearance at Full Height (mm)	99" (2515)	99" (2515)	106.7" (2710)	106.7" (2710)
	N. Dump Reach at Full Height (mm)	20.9" (529)	20.9" (529)	22.4" (569)	22.4" (569)
	P. Width over Tires - Standard / Wide (mm)	64.7" / 79.4" (1645 / 2017)	64.7" / 79.4" (1645 / 2017)	68.4" / 77.1" (1736 / 1957)	68.4" / 77.1" (1736 / 1957)
	Q. Tire Gauge	48.4" / 62.8" (1230 / 1595)	48.4" / 62.8" (1230 / 1595)	52.4" / 60.8" (1327 / 1544)	52.4" / 60.8" (1327 / 1544)
	R. ROPS Width (mm)	53.9" (1370)	53.9" (1370)	57.1" (1451)	57.1" (1451)
	S. Ground Clearance (mm)	14.6" (370)	14.6" (370)	12.3" (313)	12.3" (313)
	T. Turning Radius with Bucket (mm)	143.2" (3637)	143.2" (3637)	155.3" (4159)	155.3" (4159)
	U. Outer Turning Radius (mm)	130.3" (3310)	130.3" (3310)	134.2" (3409)	134.2" (3409)
	V. Inner Turning Radius (mm)	62.1" (1577)	62.1" (1577)	63.8" (1620)	63.8" (1620)
	W. Articulation Angle from Center (mm)	45°	45°	45°	45°
	X. Rollback at Height	45°	45°	45°	45°
	Y. Maximum Dump Angle at Full Height	45°	45°	45°	45°
Z. Bucket Rollback at Ground	45°	45°	45°	45°	
AA. Attachment Pivot Clearance (mm)	7.5" (190)	7.5" (190)	7.5" (190)	7.5" (190)	
BB. Wheel Radius (mm)	19.5" (495)	19.5" (495)	19.5" (495)	19.5" (495)	
CC. Bucket Width - standard (mm)	66" (1676)	66" (1676)	84" (2134)	84" (2134)	
ENGINE	Engine Manufacturer	Yanmar	Yanmar	Deutz	Deutz
	Model / Number of Cylinders	4TNV98CT / 4	4TNV98CT / 4	TD 3.6 L4 / 4	TD 3.6 L4 / 4
	Displacement (L)	0.87 gal. (3.3 L)	0.87 gal. (3.3 L)	0.95 gal (3.6 L)	0.95 gal (3.6 L)
	Power (kW) @ 2300 rpm ¹	64.4 hp (48)	64.4 hp (48)	74.3 hp (55)	74.3 hp (55)
LOAD CAPACITIES	Static Tipping Load with Bucket				
	Straight (kg)	6,409 lbs. (2907)	6,743 lbs. (3059)	7,446 lbs. (3378)	7,907 lbs. (3587)
	Full Turn (kg)	4,917 lbs. (2230)	5,244 lbs. (2379)	5,778 lbs. (2621)	6,126 lbs. (2779)
	Bucket Breakout (kg)	12,661 lbf (5743)	12,661 lbf (5743)	13,020 lbf (5906)	13,020 lbf (5906)
	Operating Weight (kg)	9,080 lbs. (4119)	9,500 lbs. (4309)	10,540 lbs. (4781)	10,920 lbs. (4953)
HYDRAULICS	Work Hydraulic System Flow (L/min) STD	18.5 gpm (70)	18.5 gpm (70)	18.5 gpm (70)	18.5 gpm (70)
	High-Flow Auxiliary Hydraulics - optional (L/min)	26.0 gpm (98.4)	26.0 gpm (98.4)	30.6 gpm (115.8)	30.6 gpm (115.8)
	Work Hydraulic System Pressure (bar)	2,900 psi (200)	2,900 psi (200)	2,900 psi (200)	2,900 psi (200)
	Drive Hydraulic System Pressure (bar)	6,092 psi (420)	6,092 psi (420)	5,511 psi (380)	5,511 psi (380)
	Drive Hydraulic Reservoir Capacity (L)	19.5 gal. (73.8)	19.5 gal. (73.8)	19.5 gal. (73.8)	19.5 gal. (73.8)
OTHER	Battery	12-volt	12-volt	12-volt	12-volt
	Fuel Tank Capacity (L)	25 gal. (95)	25 gal. (95)	27 gal. (102)	27 gal. (102)
	Maximum Travel Speed (km/hr)	7/12/19 mph (11/20/30)	7/12/19 mph (11/20/30)	5/12/19 mph (8/20/30)	5/12/19 mph (8/20/30)
	Tire Size - Standard	405 / 70-20	405 / 70-20	405 / 70-20	405 / 70-20

¹ Per ISO 14396

Mustang reserves the right to make changes in specifications at any time without notice or obligation.

For more information on Mustang equipment, visit our website:
Mustangmfg.com

TIRE OPTIONS

HIGH FLOTATION



Agricultural Tires

NON-DIRECTIONAL SELF-CLEANING



On / Off Road / Industrial Tires

AG/INDUSTRIAL HYBRID UNIVERSAL



On / Off Road Tires

Mustang reminds users to read and understand the operator's manual before operating any equipment. Also, make sure all safety devices and shields are in place and functioning properly.

Mustang reserves the right to add improvements or make changes in features and specifications at any time without notice or obligation.



REFERENCE DIAGRAMS

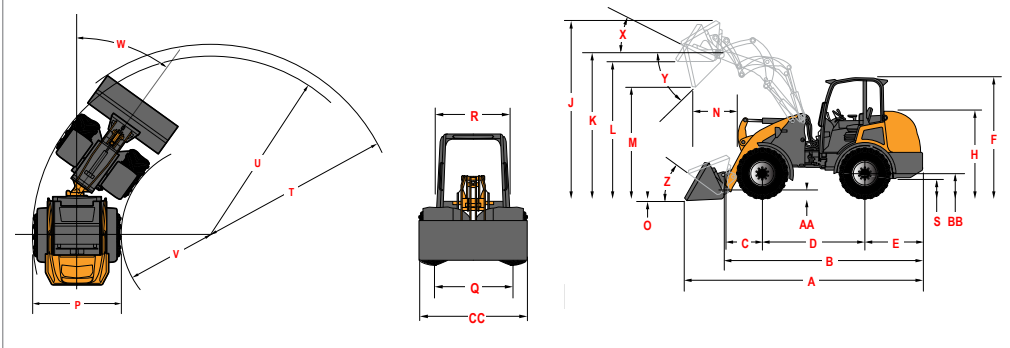

West Bend, WI 53095 U.S.A. | Tel: 262-334-9461 | Fax: 262-338-7517